



**EXECUTIVE  
SERIES™**

Executive Quick Cart is the industry's most durable mobile mini-cart solution for housekeeping, janitorial, and maintenance environments.

**Features and Benefits:**

- Repels water, oil, and stains with Teflon® fabric protector coating to maintain aesthetics and protect during daily use.
- High-performance material construction provides strength and rigidity to withstand rigorous daily use.
- Heavy-duty strap and large front pocket secures stick goods.
- Aluminum telescoping handle is dependable for heavy daily use.
- Robust ball-bearing wheels are designed for reduced noise and heavy-duty use.

**Material Composition:**

Outer Material: Polyester

Outer Material Coating: Teflon® Fabric Protector

Inner Material: Polyester

Inner Material Coating: Teflon® Fabric Protector

Support Panels: Polypropylene

**Certifications:**

None

# QUICK CART

1902465, 1902466, 1902467, 1902459, 1902468

\*All measurements in cm

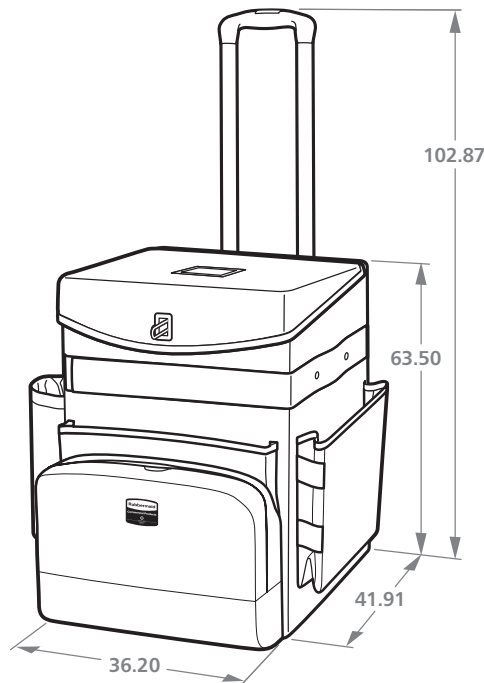

Front and Right Side (3D View)

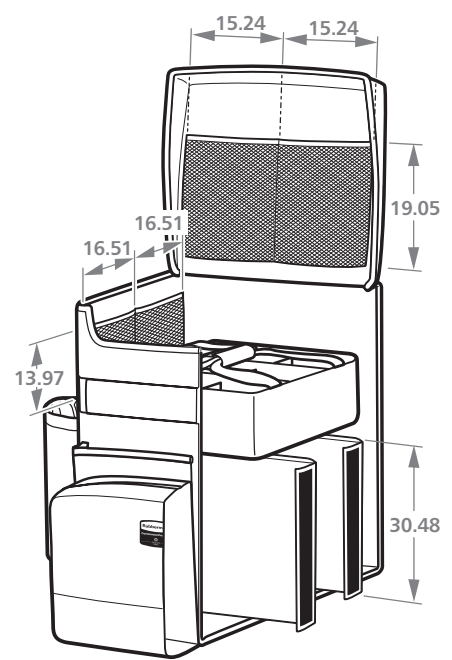

Front and Right Side (3D Cutout View)

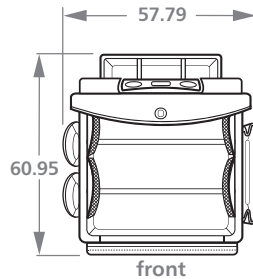

Top Down View (Open Lid)

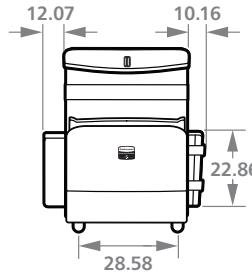

Front View

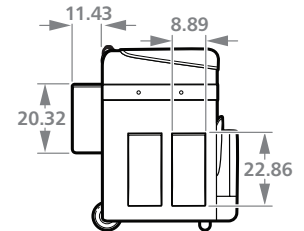

Left Side View

Description	Executive Quick Cart - Large - 1902465**	Executive Quick Cart - Medium - 1902466	Executive Quick Cart - Small - 1902467
Colour	Dark Grey	Dark Grey	Dark Grey
Product Weight* (kg)	7.80	7.17	6.53
Weight Capacity* (kg)	27.22	18.14	13.61
Total Volume Capacity (Interior)* (m <sup>3</sup> )	0.10 (0.08)	0.09 (0.06)	0.08 (0.05)
Outer Dimensions* (cm)	41.91 L x 36.20 W x 63.50 H	41.91 L x 36.20 W x 53.34 H	41.91 L x 36.20 W x 43.18 H
Other Dimensions Plus Pockets* (cm)	60.95 L x 57.79 W x 59.69 H	60.96 L x 57.79 W x 50.17 H	60.96 L x 57.79 W x 39.37 H
Interior Dimensions* (cm)	40.64 L x 31.75 W x 57.15 H	40.64 L x 31.75 W x 46.99 H	40.64 L x 31.75 W x 36.83 H
Telescopic Handle Heights (Off Ground)* (cm)	92.71 H, Position 1 102.87 H, Position 2	93.98 H, Position 1 102.87 H, Position 2	95.89 H, Position 1 102.87 H, Position 2
Front - Large Pocket* (cm)	10.16 L x 34.29 W x 29.21 H	10.16 L x 34.29 W x 25.40 H	10.16 L x 34.29 W x 22.86 H
Front - Narrow Literature Pocket* (cm)	2.54 L x 34.29 W x 29.85 H	2.54 L x 34.29 W x 27.31 H	2.54 L x 34.29 W x 23.50 H
Right - Expandable Pocket* (cm)	34.29 L x 10.16 W x 22.86 H	34.29 L x 10.16 W x 22.86 H	34.29 L x 10.16 W x 20.32 H
Left - Front Rounded Pocket* (cm)	8.89 L x 12.07 W x 22.86 H	8.89 L x 12.07 W x 22.86 H	N/A
Left - Back Lined Pocket* (cm)	11.43 L x 12.07 W x 24.13 H	10.46 L x 11.43 W x 24.13 H	N/A
Back - Full Pocket* (cm)	11.43 L x 34.21 W x 20.32 H	11.43 L x 34.21 W x 20.32 H	11.43 L x 34.21 W x 15.24 H
Back - Full Pocket Divided Sections* (cm)	8.89 L x 10.16 W x 18.42 H, Left and Right	8.89 L x 10.16 W x 18.42 H, Left and Right	8.89 L x 10.16 W x 12.70 H, Left and Right
Back - Full Pocket Height Off Ground* (cm)	28.58 H Bottom (48.26 Top)	18.42 H Bottom (38.10 Top)	17.78 H, Bottom (33.02 Top)
Interior - Lid Mesh Pockets (2)* (cm)	5.08 L x 15.24 W x 19.05 H	5.08 L x 15.24 W x 19.05 H	5.08 L x 15.24 W x 19.05 H
Interior - Right & Left Mesh Pockets (4)* (cm)	16.51 L x 5.08 W x 13.97 H	16.51 L x 5.08 W x 13.97 H	16.51 L x 5.08 W x 13.97 H
Interior - Adjustable Divider (2) (cm)	30.48 L x 33.02 W	25.40 L x 33.02 W	20.32 L x 33.02 W
Wheel Spread (cm)	28.58 W	28.58 W	28.58 W
Wheel Diameter (cm)	9.91	9.91	9.91

\*Tolerance may vary due to being sewn product

\*\*Product shown in drawing

## QUICK CART SPECIFICATIONS CONTINUED

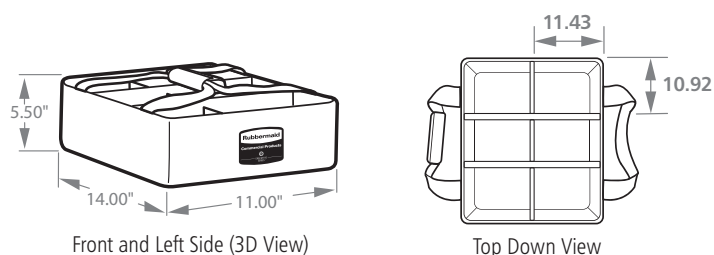

Front and Left Side (3D View)

Top Down View

\*All measurements in cm

Description	Executive Quick Cart Caddy Large - 1902468*	Executive Quick Cart Caddy Small - 1902459
Colour	Dark Grey	Dark Grey
Product Weight (kg)	1	0.65
Weight Capacity (kg)	6.8	4.5
Interior Volume Capacity (m <sup>3</sup> )	0.01	0.006
Outer Dimensions (cm)	35.56 L x 27.94 W x 13.97 H	26.67 L x 27.94 W x 13.97 H
Interior - Adjustable	33.02 L x 22.86 W x 12.70 H	22.86 L x 22.86 W x 12.70 H
Divider Dimensions (cm)	Up to 6	Up to 4

\*Product shown in drawing

## QUICK CART PACKAGING SPECIFICATION GUIDE

Description	Executive Quick Cart - Large - 1902465	Executive Quick Cart - Medium - 1902466	Executive Quick Cart - Small - 1902467
Carton Weight (kg)	9.5	8.7	7.8
Carton Cube (m <sup>3</sup> )	0.15	0.13	0.10
Carton Dimensions (cm)	57.48 L x 39.7 W x 66.04 H	57.48 L x 39.7 W x 57.15 H	57.48 L x 39.7 W x 46.36 H
Carton Quantity Per Pallet	4	4	4

## ASSEMBLY INSTRUCTIONS

Assembly instructions are provided with Quick Cart packaging. Instruction manual can also be downloaded by visiting [www.rubbermaidcommercial.com.au](http://www.rubbermaidcommercial.com.au)

## CARE INSTRUCTIONS

### Cleaning of interior / exterior surfaces and materials

Use mild soap and water with lint-free cloth or sponge to wipe down surfaces.

## ACCESSORIES & REPLACEMENTS

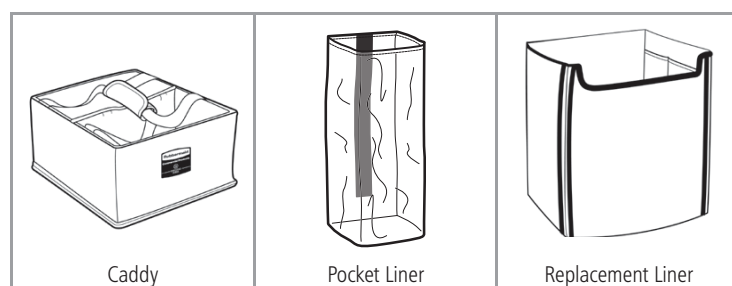

Caddy

Pocket Liner

Replacement Liner

### CADDIES

No	Colour	Description
1902468*	Dark Grey	Executive Quick Cart Caddy, Large
1902459**	Dark Grey	Executive Quick Cart Caddy, Small

### LINERS

No	Colour	Description
1919270***	Clear	Executive Quick Cart Plastic Pocket Liner
1902701	Black	Executive Quick Cart Replacement Liner, Large
1902702	Black	Executive Quick Cart Replacement Liner, Medium
1902703	Black	Executive Quick Cart Replacement Liner, Small

\* Replacement for Medium and Large Executive Quick Carts.

\*\* Replacement for Small Executive Quick Carts.

\*\*\*Replacement for all Executive Quick Carts.

## COMPLEMENTARY PRODUCTS

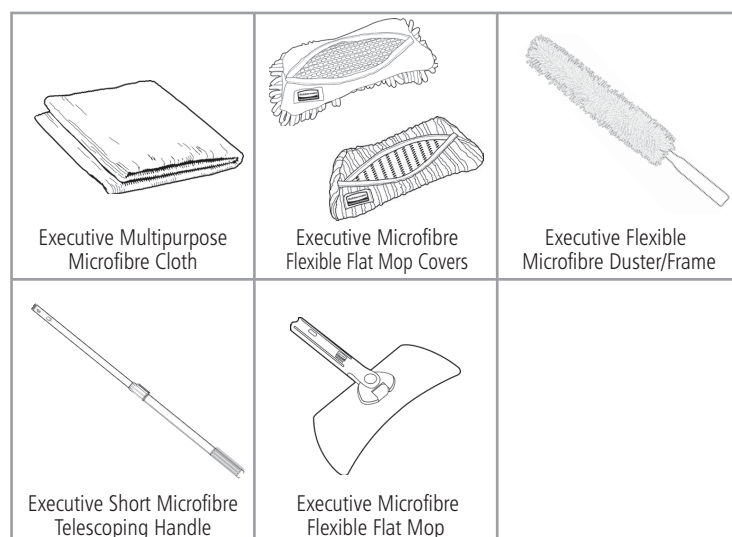

Executive Multipurpose Microfibre Cloth

Executive Microfibre Flexible Flat Mop Covers

Executive Flexible Microfibre Duster/Frame

Executive Short Microfibre Telescoping Handle

Executive Microfibre Flexible Flat Mop

### SURFACE CLEANING

No	Colour	Description
1863889	Grey	Executive Multipurpose Microfibre Cloth
1867398	Grey	Executive Glass Microfibre Cloth
FGQ85200WH00	White	Executive Flexible Microfibre Hi-Pile Duster & Frame

### HARD FLOOR CLEANING

No	Colour	Description
FGQ85500BK00	Black	Microfibre Flexible Flat Mop Frame
1863883	Silver	Executive Short Microfibre Telescoping Handle
FGQ86100WH00	White	Executive Microfibre Flexible Dust Cover (Hi-Pile)
FGQ87100BL00	Blue	Executive Microfibre Flexible Dust Cover (Glass)
FGQ88100YL00	Yellow	Executive Microfibre Flexible Dust Cover (Scrub)
FGQ89100BL00	Blue	Executive Microfibre Flexible Dust Cover (Damp)