

UP TO 20KG / CASTOR

SPRING LOADED UNIVERSAL & GATE CASTORS

Richmond's Spring Loaded Universal & Gate Castors are designed to make opening and closing of residential gates easier.

The spring loaded design provides shock absorption features specifically for use on uneven surfaces. The gate mount is integrated into the frame of the castor for ease of fixing to any gate system.



S4022

SPECIFICATIONS

Diameter (mm) A	Width (mm)	Wheel Type	Wheel Code	Bearing Type	Load Capacity (kg)	Height (mm) B	Swivel Radius C	Swivel Code
75	30	Reb Rubber	RR3348	Ball	20	259	175	S3022
75	30	Nylon	NY3321	Plain	20	259	175	S3024
75	25	Nylon	NY3324	Plain	25	100	65	S3712SPR
100	30	Reb Rubber	RR4473	Ball	20	285	190	S4022
100	30	Nylon	NY4417	Plain	20	285	190	S4024
125	30	Reb Rubber	RR5573	Ball	20	311	205	S5022

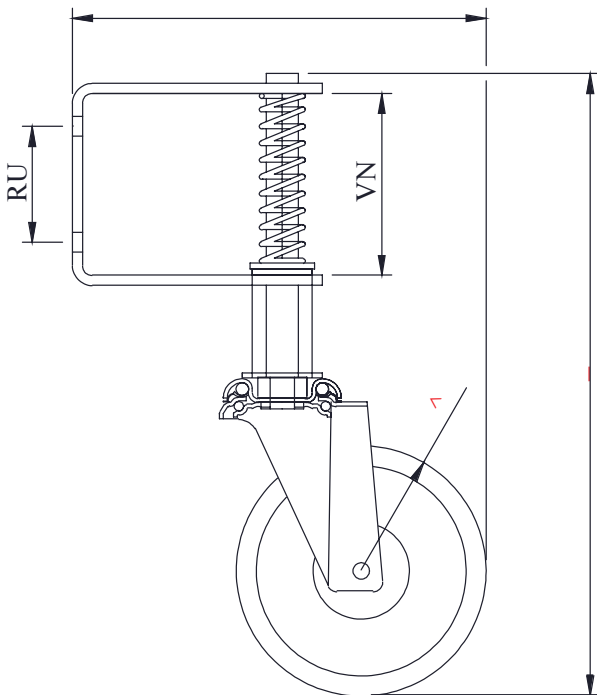

S3712SPR



S3022